

SHIPMASTERS INFORMATION AND EMERGENCY PROCEDURE GUIDE

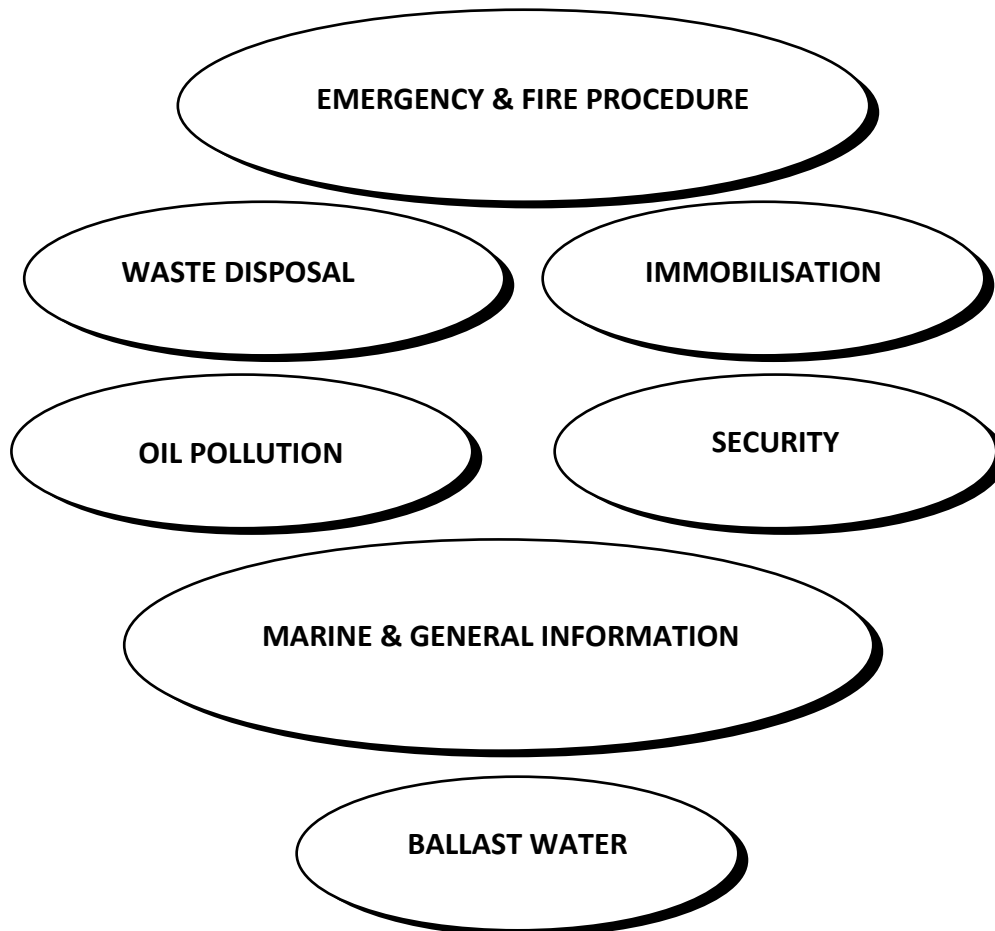

ISSUED BY
THE PORT OF FELIXSTOWE
August 2017

© All our rights reserved. No part of this publication may be reproduced, stored in a retrieval system or transmitted, in any form or by any means, electronic, mechanical, photocopying, recording or otherwise, without the prior written permission of the Port of Felixstowe Limited.

INDEX

	Page
SECTION I - MARINE EMERGENCY PROCEDURES	2
SECTION II - SECURITY PROCEDURES	4
SECTION III - WASTE DISPOSAL FACILITIES	6
SECTION IV - POLLUTION	10
SECTION V - BALLAST WATER	12
SECTION VI - IMMOBILISATION OF MAIN ENGINES	13
SECTION VII - MARINE INFORMATION	14
SECTION VIII - TOWAGE	16
SECTION IX - BERTHING INFORMATION	17
SECTION X - BUNKERING	21
SECTION XI - DIVING	22
SECTION XII - GENERAL INFORMATION	23
SECTION XIII - SAFETY INSTRUCTIONS FOR CREW	28
SECTION XIV - USEFUL TELEPHONE NUMBERS	31

SECTION I

MARINE EMERGENCY PROCEDURES

In any emergency notify Harwich VTS on VHF Channel 71 and Felixstowe Dock Tower on VHF Channel 74 giving the following information:

- i) Name of Ship
- ii) Berth
- iii) Nature of Emergency – such as man overboard, injury to person(s), contact with quay cranes etc.

(Harwich VTS will also inform the Felixstowe Dock Tower Duty Marine Supervisor who will initiate the Port Emergency Procedures).

IN THE EVENT OF FIRE:

IN ADDITION TO THE ABOVE

1. Sound seven (7) or more short blasts followed by one (1) prolonged blast on the ships whistle/siren.
2. Repeat the above signals at intervals.

The Port of Felixstowe maintains its own Fire and Ambulance Service which is available in an emergency on a 24 hour basis. It can be contacted through Felixstowe Dock Tower on VHF Channel 74 or directly by telephone – mobile or external phone +44 (0)1394 604300.

The Master should ensure all crew and/or passengers are familiar with ships' alarm signals and evacuation procedures.

The Master is reminded that under the SOLAS Regulations, he should at all times maintain a list of hazardous goods on board his vessel and also that stability information and safety plans should be readily available for use by the Emergency Services.

There is always at least one fire tug contracted to be in the harbour.

SECTION II

SECURITY PROCEDURES

Port of Felixstowe ISPS details:

IMO Port Facility Number	GBFXT-001
Port Facility Security Officer:	Chief Inspector John Whitby +44 (0)1394 604744 whitbyj@fdrc.co.uk

All vessels should comply with the measures detailed in SOLAS Ch X1-2 and the International Ship and Port Facility (ISPS) Code to enhance maritime security.

All vessels on an international voyage arriving at a UK Port must comply with EU Regulation 725/2004 regarding provision of security information.

This information must be reported through the Consolidated European Reporting System (CERS) using the CERS Workbook, or an alternative approved method (such as Destin8).

In addition to the security information, the Crew List (FAL 5) and the Passenger List (FAL 6) must be supplied prior to arrival.

The vessel's gangway must be manned at all times whilst the vessel is alongside, and all visitors must be verified and logged.

Ships' crew – shore leave

The Port of Felixstowe understands that it is important that the rights and needs of seafarers are considered. This includes security measures not unduly inhibiting seafarers' ability to access shore facilities.

To assist with the smooth operation of transporting crew into and out of the ISPS Restricted Area, Masters are reminded that only the following photographic identity documents are acceptable forms of identity for crew members who take shore leave at the Port of Felixstowe:

Passport

Ship's Photographic Identity Card or Seaman's Book

Photocopies of documents **will not** be accepted

All identity documents will be checked on entry and egress from the Restricted Area along with a cross check with the submitted Crew List.

SECTION III

WASTE DISPOSAL FACILITIES

The attention of Shipmasters is drawn to the Merchant Shipping and Fishing Vessels (Port Waste Reception Facilities) Regulations 2003 the (Amendment) Regulations 2009 and any subsequent amendments to the Merchant Shipping and Fishing Vessels (PWRF).

In accordance with these Regulations, all vessels bound for Felixstowe shall complete a notice in the form of Schedule 2 of the Regulations or in a form substantially to the like effect. Masters should advise their Agent who will forward this information to the Port by use of the Felixstowe Port Community System (Destin8). Employing an Agent for this duty does not absolve the Master of the responsibility for the delivery of the information to the Port.

All vessels calling at the Port of Felixstowe will be required to pay a charge towards the cost of Waste Reception Facilities in the Port as per the table below. Some vessels, which are frequent and regular callers at the Port, may apply for exemption from the Secretary of State via the Maritime and Coastguard Agency and upon receipt of proof of such exemption the Port will waive this charge for so long as the exemption is in force.

In the Port of Felixstowe all exemption certificates should be sent to the Portmaster. No refunds will be given for any call made before the certificate is received by the Portmaster's office.

Table of Charges for Waste Reception

	Up to 175m loa	Vessels over 175m loa	
All Ships	*£40.95	*£80.55	per call

* Correct at June 2017

These charges include the cost of disposal of reasonable quantities of waste (up to 6m³).

All ships wishing to dispose of every other type or quantity of ship generated waste, including oily and cargo wastes and residues or dunnage, should continue to make arrangements directly with commercial contractors and remit full payment for those services directly to them. Please be reminded that in the case of oil, oil-water mixes and other oily wastes, only a contractor approved by the Port of Felixstowe may operate within the Port.

The charging structure described above is considered to be both the most flexible and also the most economical to our customers whilst still observing the law. However it must be recognised that both the method of applying the regulations and also the charges made may need to be modified from time to time if circumstances dictate.

The Port Waste Management Plan may be found on the portoffelixstowe.co.uk website.

Dumping of Waste

Attention of Masters is drawn to the need to ensure that no solid waste matter is to be discharged or allowed to fall into the water.

Reception facilities are provided for reasonable bagged quantities of the following:

1. Food wastes and other materials contaminated by such wastes, generated on board ship principally in the galley and dining areas, should be placed in the specially designated skips provided, marked 'Food Waste' only.
2. Refuse generated in living spaces of crew and passengers, principally paper products, glass, rags, bottles and plastics etc, should be placed into the correct waste bins, as indicated by the pictures on the bins.

Skips are located on the terminal on specially designed mafi trailers with segregated waste bins, which can be delivered to a vessel.

These can be arranged prior to arrival or by calling directly to the terminal operations or Felixstowe Dock Tower.

OTHER WASTES

- i) For large quantities of 1 or 2 above and
- ii) For cargo associated wastes, vessel maintenance wastes and cargo residues not defined or listed in any other annex or MARPOL Convention.

Procedure

Masters should request their Agents to make arrangements for appropriate facilities with a collecting agency.

Disposal of Pyrotechnics

Masters who require to dispose of pyrotechnics or similar items should arrange removal through their Agents via a licensed pyrotechnic supplier.

Under no circumstances should they be disposed of into garbage skips or other waste reception facilities provided on the quayside.

SECTION IV

POLLUTION

Oil Pollution

Masters of vessels are reminded that the principal causes of oil pollution are through leaking shipside valves, cargo/bunker overflows and from the pumping of engine room bilges. It is therefore recommended that overboard discharges should be shut prior to berthing. Scuppers and other openings must be blocked off whilst loading/discharging bulk oil or while bunkering (Bye-Law 44). Any oil spillage should be notified immediately to Harwich Haven Authority on Channel 71 VHF and Felixstowe Dock Tower on Channel 74 if vessel is alongside.

MASTERS ARE REMINDED THAT IT IS AN OFFENCE:

- 1. TO CAUSE OIL TO BE SPILLED INTO THE WATER**
- 2. NOT TO REPORT ANY SPILLAGE AS SOON AS IT OCCURS**

Oil Pollution, Ship Cleaning

In the event of an oil spillage into the water, all local resources will be deployed immediately to contain and to recover that oil and to prevent further contamination of the environment.

Vessels contaminated by oil may be refused permission to sail until they are cleaned.

Masters are reminded that to allow oil into the water will constitute an offence in law and that they and any contractor employed in ship cleaning will be liable to prosecution should this occur during ship cleaning operations.

Emissions

The port is situated within the North Sea Emission Control Area (ECA) and vessels should comply with the Emission Regulations as defined by Annex VI of the 1997 MARPOL protocol.

Vessels alongside are also subject to Section 1 of the Clean Air Act 1993 which prohibits the emission of dark or black smoke. The maximum fine for each offence is £5,000.

Smoke and other exhaust emissions are a hazard to health, even at low concentrations. Should your vessel produce such emissions as to prevent cargo operations you will be requested to:

- a) stop the source of the smoke, or
- b) turn your vessel around, to allow cargo operations to resume.

All costs incurred will be to the vessel's account.

SECTION V

BALLAST WATER

The International Convention for the Control and Management of Ships' Ballast Water and Sediments (BWM Convention) enters into force on 8th September 2017.

All vessels will have to implement a Ballast Water Management Plan and carry a Ballast Water Record Book.

It is an offence to cause pollution or fouling of the water of the Port.

Unless the Master is confident his ballast water has been exchanged (D1 Standard) or treated (D2 Standard) and meets the required standards, de-ballasting should not take place.

The Master must present the vessel's Ballast Water Record Book and Ballast Water Management Plan to the Portmaster, or his deputy, upon request.

SECTION VI

IMMOBILISATION OF MAIN ENGINES

Where the Master of a vessel requires to immobilise main engines for repairs, the Master/Agent must seek permission from the Port of Felixstowe Portmaster or, in his absence, Duty Marine Supervisor, in writing.

Permission to immobilise will only be granted subject to the following conditions being met:

1. The vessel will not discharge/load or have remaining on board any Class 1 cargo.
2. The vessel rigs emergency towing lines fore and aft.
3. The vessel agrees to pay all costs, including towage and pilotage for any reason incurred as a result of immobilisation.
4. Repairs to be completed before completion of cargo operations.
5. Dock Tower (Duty Marine Supervisor) is advised when repairs commence and are completed.

SECTION VII

MARINE INFORMATION

(To be used in conjunction with Harwich Haven Authority requirements)

Additional copies of the Ports General Bye-Laws, berth plans and this publication are available on request from the Dock Tower, Felixstowe.

Masters are reminded that Harwich Haven Authority regularly publishes local Notices to Mariners. Copies of these can be obtained by application to the HHA VTS service. Masters may also wish to enter the Harwich Haven Authority website, (www.hha.co.uk), which contains all current local Notices to Mariners and other important information useful to all shipping navigating within the Haven area.

Pilotage

The Harwich Haven Authority provides pilotage in the Port of Felixstowe and approaches.

Pilotage is compulsory for all vessels over 50 metres in length although, subject to conditions, Pilotage Exemption Certificates may be obtained.

Masters are reminded that the booms of ship to shore cranes may extend well beyond the side of vessels on berth. Furthermore, ships often swing cranes outboard when working cargo. All vessels are required to pass no closer than 30 metres from the end of any extended boom.

Vessels required to warp along the quay for cargo operations, or any other purpose, need not take a pilot as long as at least one mooring line is fast upon the quay at all times.

However it is recommended that for large vessels over 240 metres, that need to move more than 1 bollard length, a pilot and tugs are used.

All vessels of 50 metres or more moving along the quay, with no lines fast on the quay, are subject to compulsory pilotage.

Pilots used for sailing or shifting require 2 hours notice. Telephone +44 (0)1255 243111.

Full details are obtainable from:

The Harbour Master
Harwich Haven Authority
Navigation House, Angel Gate
Harwich, Essex C012 3EJ

SECTION VIII

TOWAGE

Tug availability

Svitzer Towage operate tugs and they listen in on VHF 10/12/16/71/74.
working channel is VHF 10 + 12.

Full details, including rates, are available from the company.

Svitzer Towage Limited
Wickenden House
Felixstowe
Suffolk IP11 3TZ Telephone: + 44 (0)1394 613162

Tugs generally available to Port of Felixstowe – August 2017

Svitzer Kent	80T Bollard Pull
Svitzer Deben	80T Bollard Pull
Svitzer Sky	70T Bollard Pull
Svitzer Shotley	70T Bollard Pull
Gray Test	17T Bollard Pull

SECTION IX

BERTHING INFORMATION

The Dock Tower is the co-ordination point for marine activities within the Port of Felixstowe.

From the Tower, Marine Supervisors maintain liaison with and provide information to Harwich VTS, pilots, terminals, agents and tugs, control deployment of Shipmoorers and provision of watering services and waste reception.

Felixstowe Marine Supervisors continuously update HHA VTS with berthing requirements. Information is available via HHA radio and direct from Felixstowe Dock Tower, or Port of Felixstowe website (www.portoffelixstowe.co.uk)

Marine Supervisors communicate direct with vessels, particularly for positioning on the berth, when vessels are in close proximity or alongside berth, via VHF Channel 74, 12 and 10.

At other times communications should be via Harwich VTS, which will, if required, relay information to Felixstowe Dock Tower by direct line.

Shipmoorers

Shipmoorers are provided by the Port of Felixstowe and their deployment is under the control of the Marine Supervisor and the Stevedore Shift Supervisor.

Contact via Harwich VTS, VHF Ch 71, or direct to Felixstowe Dock Tower on VHF Channel 74.

All ships must be made fast and let go by the properly appointed employees of the Port of Felixstowe.

A Marine Supervisor will attend all berthing/unberthing and any other marine operations.

Dooley Terminal will provide their own berthing team for RoRo 3 and 4. When the Dooley Team is unavailable, the Marine Supervisor will attend with the mooring gang.

Precautions when sailing

Masters are advised that when shipmoorers attend a vessel for sailing, they are not permitted to let any ships ropes go until the ship to shore cranes adjacent to that vessel have housed the boom in the vertical position. Any exception to this rule will require the authorisation of the Duty Marine Supervisor.

Heaving lines

Masters are advised that the use of heavy weights as part of the monkey's fist on the end of heaving lines is considered an unsafe practice and in addition to confiscation of the monkey's fist, the Master may be liable to prosecution in the event of injury or damage to Port personnel/property.

Mooring ropes:

1. When sending mooring lines ashore there should be sufficient slack for the Shipmoorers to gather a bight on the quay and to lead the eye to the bollard without undue strain. Likewise crew should not allow long lengths to fall into the water, which creates a heavy strain on those heaving it on to the quayside. Crew should not heave on ropes until signalled by the mooring party.
2. Shipmoorers are under instruction not to heave on lines when so doing will create a health and safety risk for them.
3. Vessels should deploy sufficient moorings in terms of number and strength to keep the vessel safely alongside for the duration of the stay, taking into consideration the anticipated wind direction and strength likely to be encountered.

Particular consideration should be given to the actual and anticipated configuration of deck cargo, and the forces generated by beam winds.

4. Vessels berthed at the north end of Trinity Terminal on berth 5, 6 and 7, should pay particular attention to their moorings, as there could be possible interaction between their own and passing vessels. They should also fly the international flag signal 'RY' – 'Please reduce speed whilst passing' during daylight hours.

All mooring ropes are to be of sound construction and adequate for the purpose for which they are used.

The prevailing wind direction is south westerly.

BERTH NAMES AND DEPTHS

Berth	Bollard Range	Maintained Depth	Maximum Draught
Trinity 1	20.5 – 28	11.6 m	11.3 m
Trinity 2	28 – 40	11.9 m	11.6 m
Trinity 3	40 – 43	11.9 m	11.6 m
Trinity 3	44 – 59	14.0 m	13.7 m
Trinity 4	60 – 76	14.0 m	13.7 m
Trinity 5	76 – 94.5	14.0 m	13.7 m
Trinity 6	100 – 123	15.0 m	14.7 m
Trinity 7	123 – 147	15.0 m	14.7 m
Berth 8	31 – 49	16.0 m	15.7 m
Berth 9	12 – 31	16.0 m	15.7 m
RoRo 3	1 – 9	7.3 m	7.0 m
RoRo 4	10 – 20	9.75 m	9.45 m
Dooley	10 – 20	9.75 m	9.45 m

All berths are subject to silting.

Bollard Rating

Trinity	bollard 1 – 24	50 T
	bollard 25 – 130	100T
	bollard 131 – 147	150T
Berth 8 & 9	Bollard 12 – 49	200T (double bollards)

SECTION X

BUNKERING OPERATIONS

See Bye-Laws 31, 41 and 44

- i) Bunkering by barge or road tanker will only be permitted by the Portmaster or his deputy, when he is satisfied that the proposed bunkering operation will comply with all Port of Felixstowe requirements, for which purpose the ship's agent should request permission to bunker not less than 48 hours before the proposed operation.
- ii) The Port of Felixstowe cannot accept any responsibility for any bunkering operation being cancelled, curtailed or delayed for any reason whatsoever.
- iii) The ship taking bunkers will not be permitted to retain its berth for that purpose beyond the normal time required to carry out cargo operations.
- iv) All aspects of the bunkering operation including, but not restricted to, making fast and letting go, fendering, connecting and disconnecting pipelines and pollution control are the responsibility of the Master of the ship receiving bunkers.

Bunkering operations in the hours of darkness will not normally be permitted, except under exceptional circumstances at the discretion of the Portmaster or his deputy.
- v) Full details of requirements for bunkering by barge can be obtained on application to the Marine Supervisor – Tel: +44 (0)1394 604724 or email docktower@fdrc.co.uk.
- vii) Permission must be sought from Harwich VTS.

SECTION XI

DIVING ACTIVITIES

No diving activities may take place anywhere in the Port area without the written permission of the Portmaster or the Marine Supervisor.

This permission will only be given:

1. Provided the Port of Felixstowe Diving Regulations and Procedures are complied with fully.
2. Upon receipt of a properly completed and signed copy of the Diving Permission form - copies available on request from the Dock Tower.

Failure to observe any regulation or Port requirement will result in immediate suspension of permission to operate.

The Port of Felixstowe accepts no responsibility for the safety of personnel, quality of workmanship or any other aspect of any diving operation not undertaken under contract with the Port of Felixstowe.

The Dock Tower and Harwich VTS must be informed when diving operations commence, and again on completion of operations.

SECTION XII

GENERAL INFORMATION

Medical and First Aid facilities

A fully equipped Medical Centre is located on the Port, where there is a qualified nurse on duty between the hours of 0730-1700 (weekdays). First aid and ambulance facilities are also available at the Port Fire Station (on a 24 hour basis) which is located midway along Dyke Road. Contact via Felixstowe Dock Tower on VHF Channel 74.

EMERGENCY NUMBER +44(0)1394 604300

Rabies control

The importation or landing of unlicensed animals into the United Kingdom is prohibited. Ensure that all animals are confined on board and under no circumstances must they be allowed ashore. If any animal escapes, this must be reported immediately to the Port Police (Tel No. +44 (0)1394 604747).

Rat guards must be placed on every mooring rope.

On-board access

All deck surfaces used for movement about the ship and all passageways, walkways, stairs and ladders should be in good order and kept free from obstruction and from substances liable to cause a person to slip or fall. Spillages of oil or grease, etc. should be cleaned up as soon as possible.

Hatches, gratings and safety rails should be in good order, properly rigged and secured, and suitable for their designed purpose.

All lashing areas for stevedores/crew must be provided with adequate fall protection, properly maintained and in good order.

Gangways and accommodation ladders

It is the ship's responsibility to ensure that the gangway or accommodation ladder is tended at all times. Ship's gangways or accommodation ladders should be in good condition, properly rigged and deployed, adequately illuminated and safety nets must be rigged. Where reasonably practical the gangway should be grounded. A lifebuoy with self activating light and a buoyant safety line should be provided for ready use at the point of access aboard every ship.

The gangway should be manned at all times – see Section II. Port personnel will not board a ship until a safe means of access is provided.

Gangways and accommodation ladders should be deployed so as to remain clear of cranes, crane rails and other equipment and obstructions at all times.

Care should be taken at all times when boarding or leaving ships.

NO pedestrians are allowed on the terminal operational areas.

All persons ashore must wear high visibility clothing and a safety helmet. In addition, ships crew when painting or working from the quay, must wear a lifejacket and avoid passing or working under suspended loads.

Vehicle access to quays

The Port of Felixstowe is fully compliant with International Ship and Port Facility Security Code (ISPS). Access to the quayside is strictly controlled through the Port Police/Security (Tel No. +44 (0)1394 604747).

Any vehicles allowed to enter the terminal should be equipped with suitable amber flashing warning light, which should be used when passing through or working in container terminal areas.

No vehicle or its equipment, including oil hoses from road tankers, may be placed where it may impede the movement of cranes or any other vehicles, across crane rails or pedestrian walkways or where it may impede the use of gangways, bollards, water hydrants, crane anchor points, garbage skips or other equipment, without the express permission of an officer of the company.

All vehicles and drivers must comply with all port and national laws and regulations concerning the use of road vehicles and comply with any posted speed restrictions.

On board lighting and equipment

Areas of ships used for dock work shall be adequately illuminated. Unattended openings in the decks should also be kept illuminated or safely closed if not lit. Any opening, hatchway or dangerous edge through which a person may fall must be fitted with adequate fencing.

All ships' ladders and riggers' access platforms must be of good construction and properly maintained. All hatch covers shall be properly maintained and defective or damaged hatch covers should be replaced or repaired as soon as possible.

Ships' lifting plant (that is lifting appliance plus lifting gear) shall be in good condition and properly maintained. Ships' Masters should be ready to produce in date certification of lifting plant should it be required by an Officer of Felixstowe Dock and Railway Company. This also applies to ships' lift trucks.

Ships' Masters should not allow crew members to use ships' forklifts, ramps or other plant unless they are competent to do so, during dock operations.

Any queries regarding Marine Operations within the Port of Felixstowe should be made to:

Portmaster Telephone: + 44 (0)1394 604780
(Internal 4780)

or portmaster@fdrc.co.uk

**Marine Supervisor
Felixstowe Dock Tower** Telephone: +44 (0)1394 604724
(Internal 4724)
VHF: Channel 74
Email: docktower@fdrc.co.uk

Assistance

If you require assistance or further information on safety matters, contact the Shift Safety Manager on +44 (0)1394 604676 or the Port Fire Station +44 (0)1394 604731 or ext. 4731 who will assist at any time (24 hours)

Taxis

Local Taxis can be called from the Seafarers Centre. The centre is also the Port pick up and drop off point for taxis.

Local buses stop 30 metres from the Seafarers Centre.

Felixstowe Town Centre is 2.5 miles (4 km) from the Port.

SECTION XIII

SAFETY INSTRUCTIONS FOR SHIPS CREW MEMBERS

Access to and From Vessels

Under no circumstances enter the container blocks or any other working area. Do not pass under working cranes while loads are in motion over a ship's side.

Crew members wishing to go ashore or visit the Seafarer's Centre must use the FREE BUS SERVICE* provided.

NOTE: There is NO pedestrian access to the quay.

Multi-lingual leaflets describing these requirements are placed on all ships. Extra copies may be obtained from the Dock Tower, Safety Department or the Seafarers Centre.

The riding of bicycles on all quays is forbidden.

* The Seafarers' Centre is manned between 1000 and 2200 daily.

Safety during Cargo Handling Operations

It is strongly recommended that you:

- Always wear a safety helmet
- Always wear protective footwear
- Always wear a high visibility vest
- Always stay at least one container away from any container movements
- Do not work over adjacent open holds
- Keep walkways and passageways clear

SAFE WORKING PRACTICE SHIPWORKERS RIGGERS

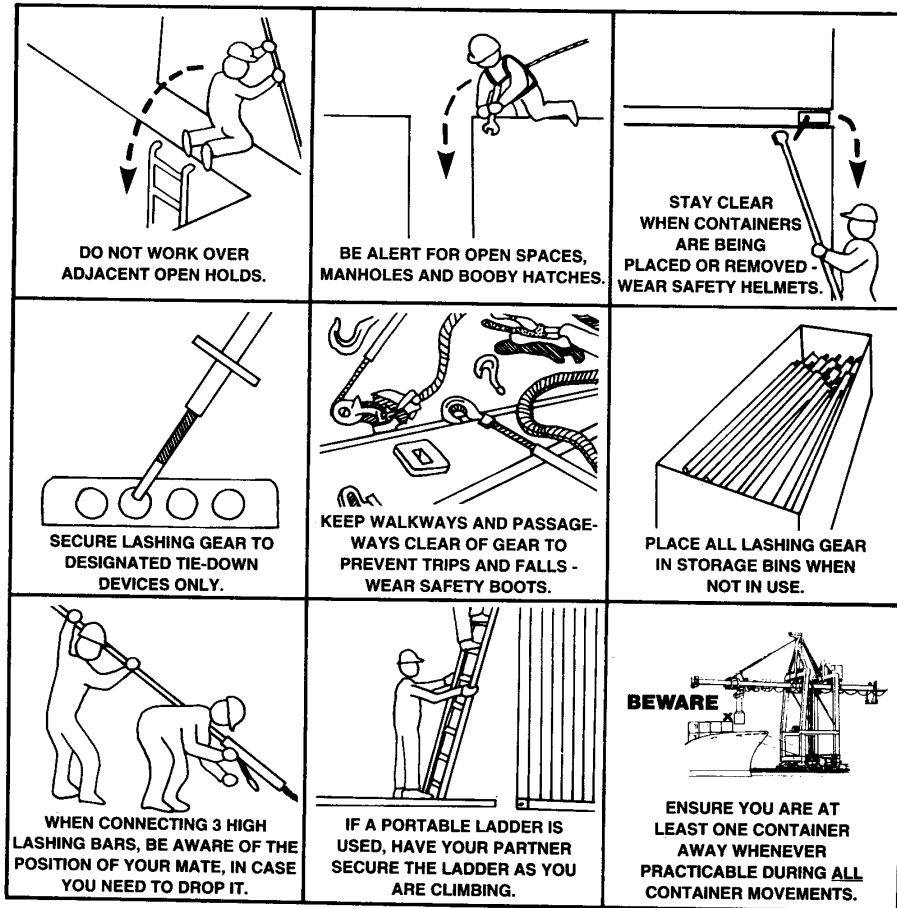

MAKE FELIXSTOWE SAFE

DON'T STAND INTO DANGER ON SHIPS

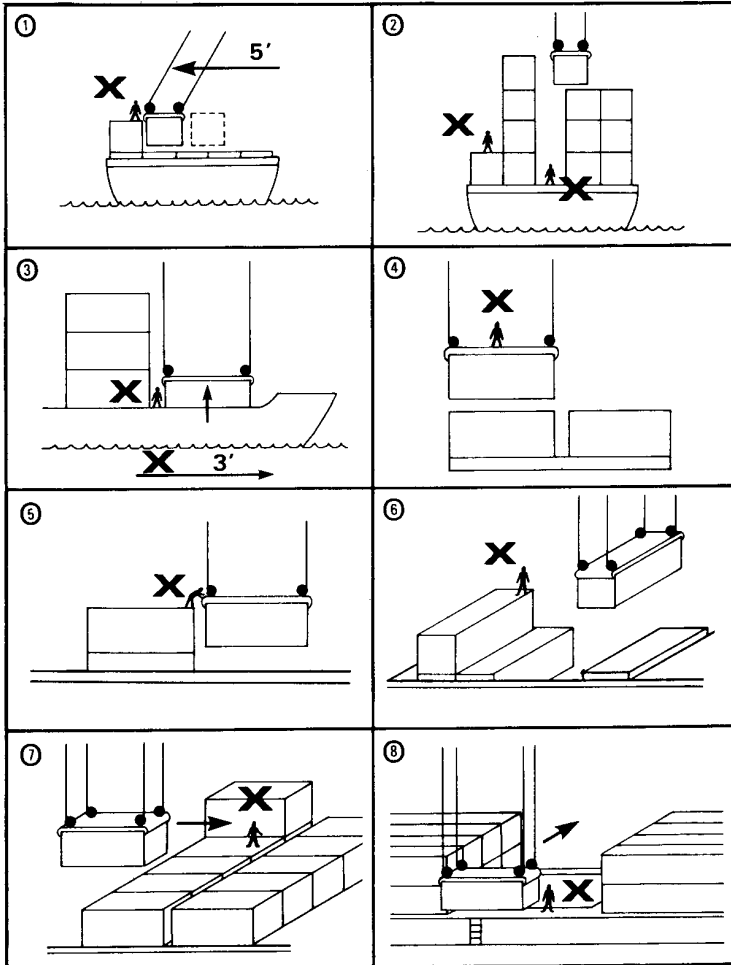

MAKE FELIXSTOWE SAFE

USEFUL TELEPHONE NUMBERS

Portmaster	+ 44 (0) 1394 604780
Dangerous Goods Officer	+ 44 (0) 1394 604532
Dock Tower	+ 44 (0) 1394 604724

EMERGENCIES

+ 44 (0) 1394 604300

Emergency Services 24 hrs – for Fire Service	+ 44 (0) 1394 604731
Safety Manager	+ 44 (0) 1394 604676/4731
Ambulance	+ 44 (0) 1394 604731
Health Centre	+ 44 (0) 1394 604742
Police Station Control Room	+ 44 (0) 1394 604747
Port Health	+ 44 (0) 1394 603469/603472
Towage: Svitzer Towage Ltd	+ 44 (0) 1394 603162

EXTERNAL

Harwich Haven Authority VTS Centre	+ 44 (0) 1255 243000
HM Customs & Excise Drugs Line	0800 595000
Seafarers Centre	+ 44 (0) 1394 673599
Bus Service	+ 44 (0) 1394 613502